

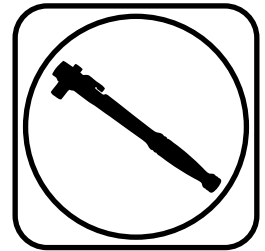

Part # 12152411 - 2005 - 2014 Mustang TQ ShockWave



Recommended Tools



2005-up Mustang Front TQ AirStrut Installation Instructions

Table of contents

- Page 2..... Included components
- Page 3..... Disassembly and Getting Started
- Page 4..... Upper Mount Assembly
- Page 5..... Final Assembly
- Page 6..... Strut Adjustment

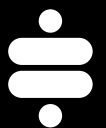



Included ComponentsIn the box

Item #	Part #	Description	QTY
1	986-10-075	Strut Cartridge	2
2	90003614	Upper Mounting Plate	2
3	90003590	Isolator Retaing Ring	2
4	70016907	Strut Mount Rubber Isolator	2
5	70010943	Lower Strut Mount	2
6	90002368	Thrust Bearing Adapter	2
7	70010987	Thrust Bearing	2
8	70010988	Thrust Bearing Washer	4
9	90001042	Upper Mount Bearing	2
10	90000805	Upper Bearing Snap Ring	2
11	99562003	9/16"-18 Nylok Nut	2
12	99055000	M5 x.8 x 5mm Set Screw (Not Shown)	2
13	234-00-153	Locking Ring (Not Shown)	2
14	21090798	Strut Air Spring	2
15	31954201	1/4" 90 Degree Fitting (Not Shown)	2
16	90002372	Sway Bar Link Mount	2
17	038-01-035	Strut Retaining Ring	2
18	99371042	3/8"-16 x 1" SHCS	6
19	99371004	3/8"-16 x 1 1/4" Hex Bolt	8
20	99372002	3/8'-16 Nylok Nut	8
21	99373003	3/8" Flatwasher	16
22	72000008	1/4"-20 x 3/4" FHSC	8
23	90000803	Eccentric Bolt	2
24	90000695	Posilink Spacer (Not Shown)	2
25	90002573	12mm 90 Degree PosiLink (Not Shown)	4
26	90009969	Adjuster know retaining screw (Not Shown)	2
27	210-35-120-0	Rebound Adjustment Knob (Not Shown)	2
28	99433002	7/16" SAE Flat Washer (Not Shown)	8

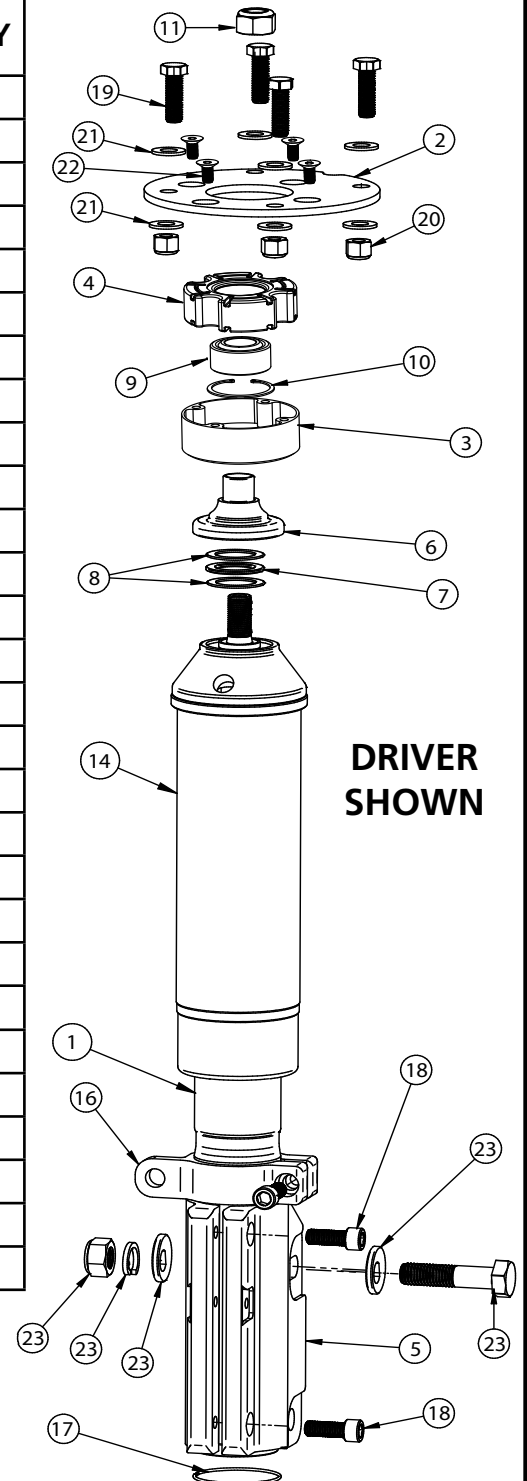



Disassembly

1. Remove the front struts by first disconnecting the ABS wire and brake line(retain hardware) from the factory strut.
2. Disconnect the swaybar linkage from the strut and swaybar this will be replaced with new linkage.
3. Support the front hub and control arm assembly and remove the (2) struts bolts(retain hardware) that attach the strut to the spindle.
4. Remove the (4) nuts holding the upper strut mount to the car body. **DO NOT REMOVE THE CENTER NUT.**
5. Remove strut assembly from the car.

Getting Started

6.

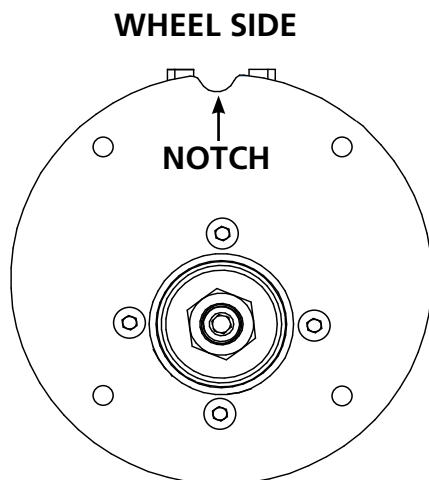

6. The upper strut mount provided in this kit has is designed to aid in tire clearance. The notch on the upper mount is positioned towards the wheel of the car.

7.

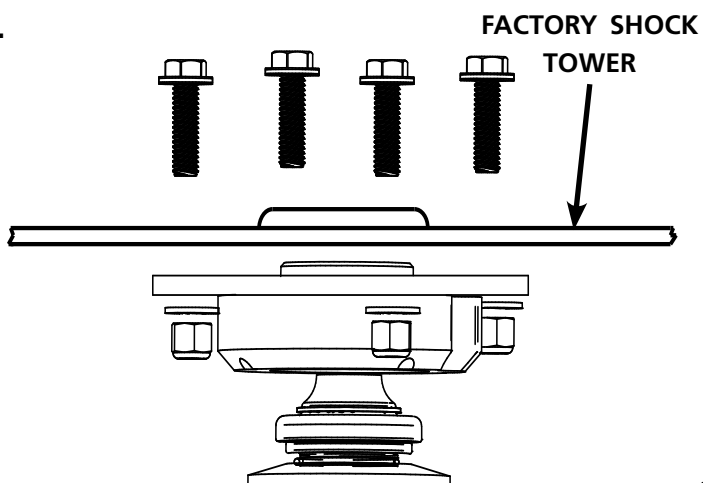

7. Bolt the upper mount into the car positioning it to the inside of the car. The camber adjustment will be done on the bottom of the strut using the supplied camber bolt. The plate gets bolted in from the bottom side of the strut tower using (4) 3/8"-16 x 1 1/4" bolts. Install a 3/8" washer on the top and bottom and secure it with (4) 3/8" 16 Nylok Nuts. Tighten all (4) down.

NOTE: The Struts are Driver and Passenger, the sway bar mount points to the rear of the car.



Upper Mount Assembly

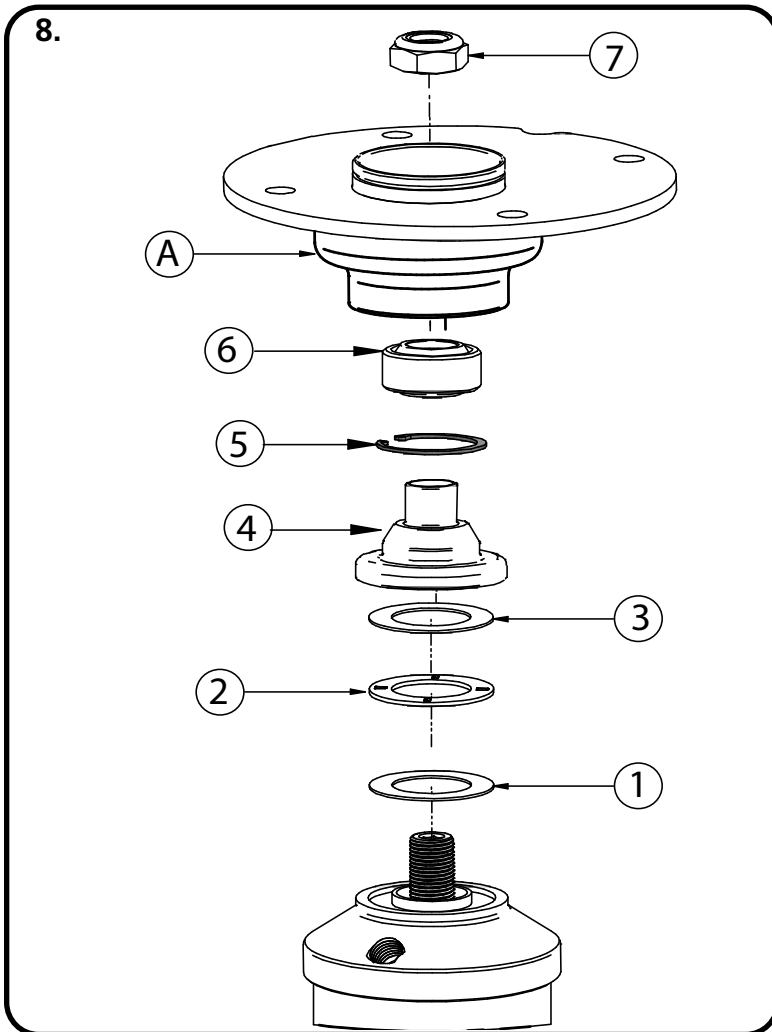

8. Install the Air fitting into the Airspring using thread tape. The Strut comes preassembled, but if for some reason you need to disassemble the strut, Figure 8 shows the assemble order. Remove the Adjuster Knob from the Strut shaft for assembly. Bolt the strut assembly into the upper mount (A), see diagram 11 for assembly order.

1. Lower Torrington Bearing Race
2. Torrington Bearing
3. Upper Torrington Bearing Race
4. Bearing Adapter (Small Diameter Up)
5. Upper Mount Bearing Snap Ring
6. Upper Mount Bearing
7. 9/16" Locknut

Assemble components and install into upper mount tightening upper nut. Reinstall upper adjustment knob

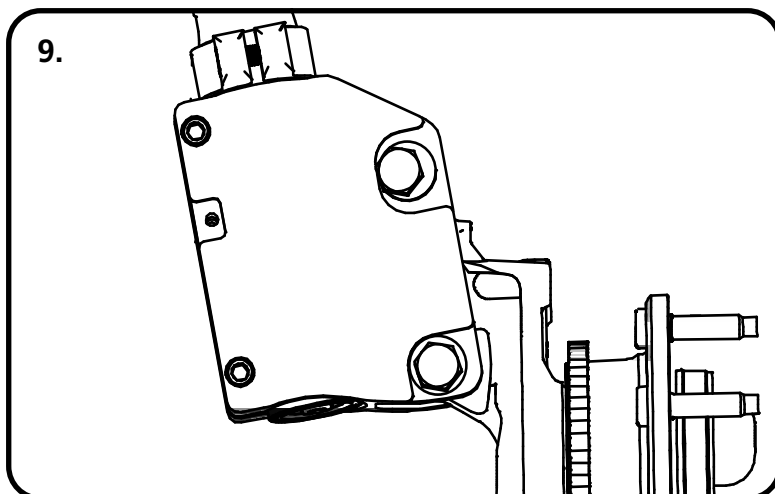

9. Slide the lower strut mount onto the spindle reusing the Factory hardware in the lower mounting hole. Insert the supplied Camber bolt into the top hole.



Assembly

10.

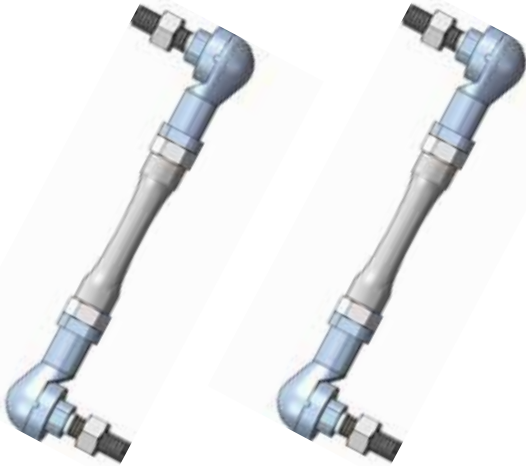

10. Attach the PosiLinks between the strut and Sway bar using the 12mm Nylok Nut. .

11.

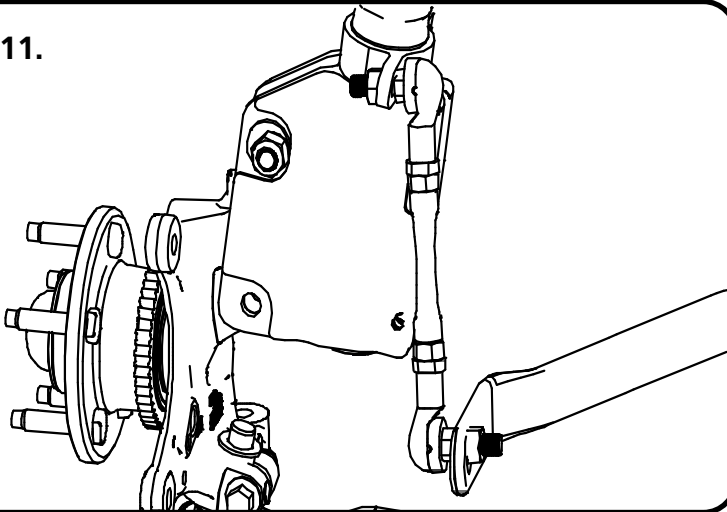

11. The Posilink mounts with the stud on the Strut pointing outward, and the stud on the Sway bar pointing in.

Note: Image is viewing the strut from rear of the vehicle.

12. Attach the brake line to the Strut using the Factory hardware.

13. Route the Airline to the Air Spring. When hooking up the Airline be sure that you can turn the steering from lock to lock with out tugging on the Airline. This situation will eventually cause the line to leak.

14. Repeat previous steps on Passenger side.



Strut Adjustment

Strut Adjustment 101- Single Adjustable

Rebound Adjustment:

How to adjust your new struts.

The rebound adjustment knob is located on the top of the Strut protruding through the upper mount.

You must first begin at the ZERO setting, then set the shock to a soft setting of 20.



-Begin with the Strut adjusted to the ZERO rebound position (full stiff). Do this by rotating the rebound adjuster knob clockwise until it stops.

-Now turn the rebound adjuster knob counter clock wise 20 clicks. This sets the shock at 20. (settings 21-24 are typically too soft for street use).

Take the vehicle for a test drive.



-If you are satisfied with the ride quality, do not do anything, you are set!

-If the ride quality is too soft increase the damping effect by rotating the rebound knob clock wise 3 clicks.

Take the vehicle for another test drive.



-If the vehicle is too soft increase the damping effect by rotating the rebound knob clock wise 3 additional clicks.

-If the vehicle is too stiff rotate the rebound adjustment knob counter clock wise 2 clicks and you are set!

Take the vehicle for another test drive and repeat the above steps until the ride quality is satisfactory.

Note:

One end of the vehicle will likely reach the desired setting before the other end. If this happens stop adjusting the satisfied end and keep adjusting the unsatisfied end until the overall ride quality is satisfactory.



Strut Adjustment

Shock Adjustment 101-Triple Adjustable

Triple Adjustable:

Step One: High Speed Compression



-High speed compression adjustments are used in both street driving and track tuning.

-Begin with the shocks adjusted to the ZERO high speed compression position (full stiff). Do this by rotating the high speed compression adjuster (large knob) clockwise until it stops.



-Now turn the high speed compression adjuster knob counter clock wise 20 clicks. This sets the shock at 20. (settings 21-24 are typically too soft for street use. For typical street driving the high speed compression adjuster will remain at setting 20.

Step Two: Low Speed Compression

Low speed compression adjustment is what is typically felt during street driving.



-Begin with the shocks adjusted to the ZERO low speed compression position (full stiff). Do this by rotating the low speed compression adjuster (small knob) clockwise until it stops.



-Now turn the low speed compression adjuster knob counter clock wise 20 clicks. This sets the shock at 20. (settings 21-24 are typically too soft for street use). Take the vehicle for a test drive.

-if you are satisfied with the ride quality, do not do anything, you are set!



-if the ride quality is too soft increase the damping effect by rotating the low speed compression knob clock wise 3 clicks.

Take the vehicle for another test drive.



-if the vehicle is too soft increase the damping effect by rotating the low speed compression knob clock wise 3 additional clicks.



-If the vehicle is too stiff rotate the low speed compression adjustment knob counter clock wise 2 clicks and you are set!

Take the vehicle for another test drive and repeat the above steps until the ride quality is satisfactory.

Step 3:

Adjust rebound according to Single Adjustable instructions.

Note:

One end of the vehicle will likely reach the desired setting before the other end. If this happens stop adjusting the satisfied end and keep adjusting the unsatisfied end until the overall ride quality is satisfactory.