



350 S. St. Charles St. Jasper, In. 47546
Ph. 812.482.2932 Fax 812.634.6632

www.ridetech.com

Part # 13046110

Mopar LX Platform Rear CoilOver – HQ Series

05-08 Magnum / 05-Up 300C / 06-Up Charger / 08-Up Challenger

Shock:

2	982-10-805	5.2" stroke shock HQ Series
2	90002156	4.7" Eyelet
8	90001995	Bearing Snap Ring (Installed in Shock Body)
4	90001994	.625" ID Bearing (Installed in Shock Body)

Components:

2	59100325	10" 325lb Coilspring
2	90002230	Steel washer for rubber mount
2	70010949	Upper rubber isolator
2	90001973	Lower rubber isolator (T-shaped)
2	90002369	Rubber Bushing Housing
1	90002738	Driver Upper Shock plate
1	90002739	Passenger Upper Shock plate
2	803-00-199	Spring Retainer kit
2	90002070	Drop Spring Cap
2	90009982	Upper Shock Mount
4	70010828	Delrin Spring Washers
4	90002043	Upper Bearing Spacers (Narrow)
4	90002443	Lower Bearing Spacers (Wide)

Hardware:

4	99502001	1/2"-13 Nylok Nut	Shock Mounting
2	99501004	1/2"-13 x 3" Bolt	Upper Shock Mount to Bushings
2	99501003	1/2"-13 x 2 1/2" Bolt	Upper Shock Mount
2	99563001	9/16" Flatwasher	Upper Shock Mount
8	99251017	1/4"-20 x 1/2" Low-Profile SHCS	Housing to Plate

Mopar LX Rear CoilOver Assembly

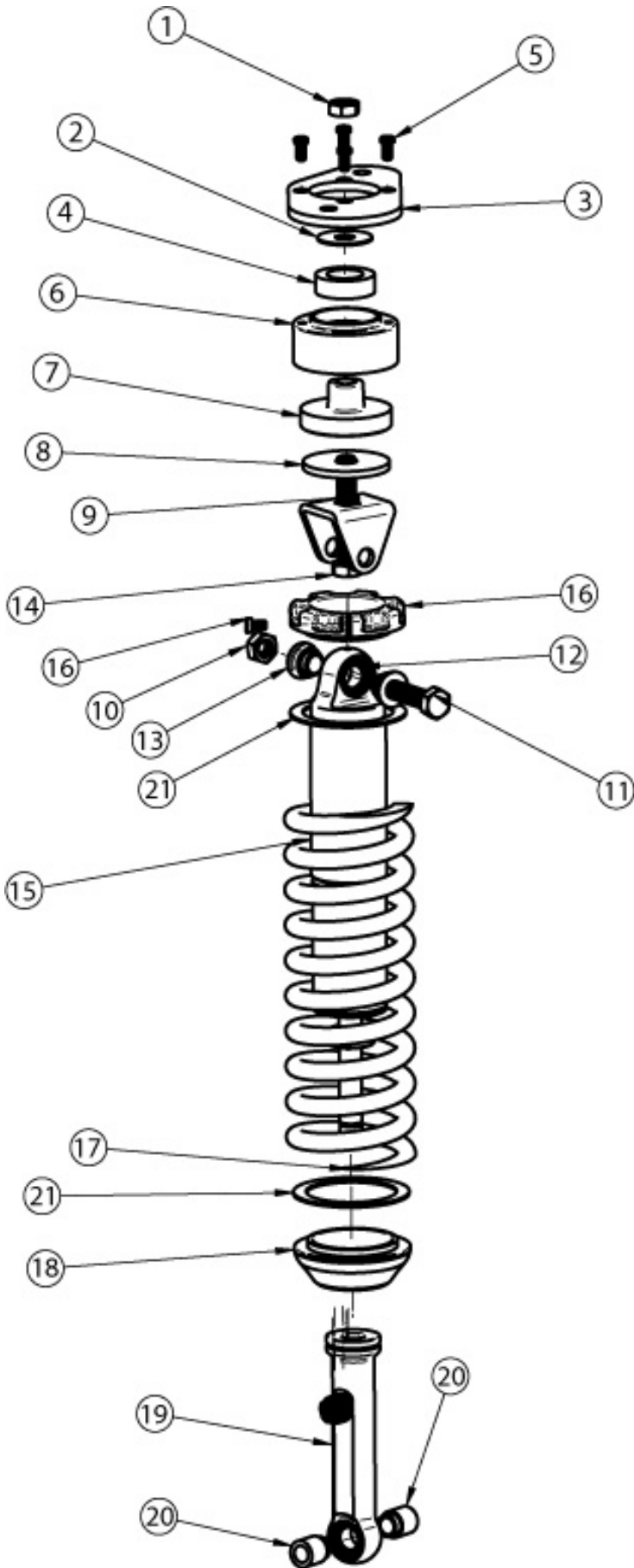

Item Number	Description	Qty.
1	1/2"-13 Nylock Nut 99502001	2
2	9/16" Flatwasher 99563001	2
3	Upper Mounting Plate 90002738 Driver	1
3	Upper Mounting Plate 90002739 Passenger	1
4	Upper Rubber Isolator 70010949	2
5	1/4"-20 x 1/2" Low Head SHCS 99251017	8
6	Aluminum Upper Mount 90002369	2
7	Lower Rubber Isolator 90001973	2
8	Isolator Washer 90002230	2
9	Upper Shock Mount 90009982	2
10	1/2"-13 Nylok Nut 99502001	2
11	1/2"-13 x 2 1/2" hex Bolt 99501003	2
12	625" ID Bearing 90001994	4
13	Upper Bearing Spacer 90002043	4
14	1/2"-13 x 3" hex Bolt 99501004	4
15	5.2" Stroke HQ Shock 982-10-805	2
16	Coilspring Retainer kit 90002222	2
17	10" 325lb Coil Spring 59100325	2
18	Drop Coil Spring Cap 90002070	2
19	4.7" Eyelet 90002156	2
20	Lower Bearing Spacers 90002443	4
21	Delrin Spring Washers 70010828	4

COILOver

Installation Instructions

1. Raise the vehicle to a safe and comfortable working height with the suspension hanging freely.
2. Remove the factory springs, shocks and upper mounts, refer to the service manual for proper disassembly procedures. **Retain the factory upper hardware for reassembly.**
3. Assemble the CoilOver using the drawing on the previous page as a reference.

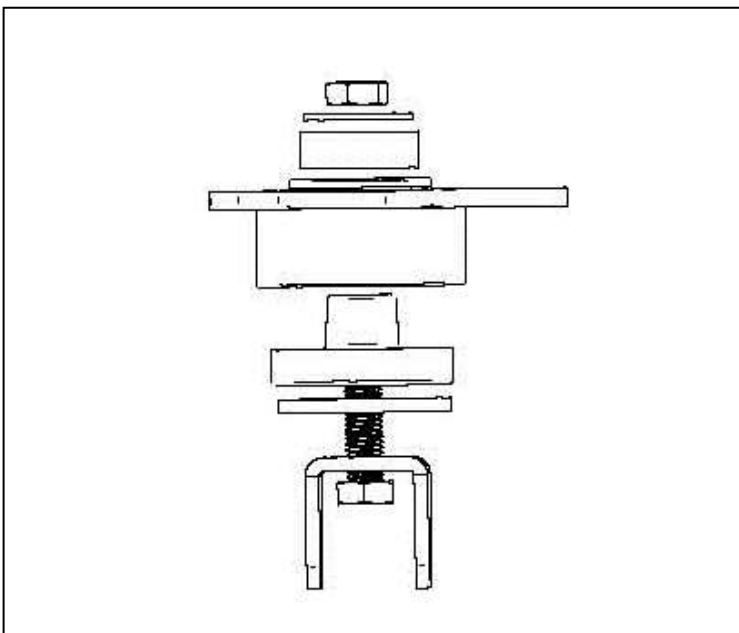

4. Assemble the upper shock mount using the illustration as a reference. **The upper shock bolt must run parallel with the lower shock bolt.**

Note: The upper shock bolt must run parallel with the lower shock bolt.

5. Assemble the spring onto the shock. Slide the upper mount over the eyelet. Install the retaining snap ring.



6. Install the CoilOver assembly into the upper mount with a narrow spacer in each side of the bearing. Attach it to the upper mount using a $\frac{1}{2}$ " x $2\frac{1}{2}$ " bolt.

7. Bolt the assembly to the body of the car using the factory hardware.



8. Attach the eyelet to the lower control arm using a wide spacer in each side of the bearing. Attach the eyelet using the OEM bolt and OEM nut.

Note: Locate the adjuster knob facing the rear of the car.

Ride Height

We have designed most cars to have a ride height of about 2" lower than factory. To achieve the best ride quality & handling, the shock absorber needs to be at 40-60% overall travel when the car is at ride height. This will ensure that the shock will not bottom out or top out over even the largest bumps. Measuring the shock can be difficult, especially on some front suspensions. Measuring overall wheel travel is just as effective and can be much easier. Most cars will have 4-6" of overall wheel travel. One easy way to determine where you are at in wheel travel is to take a measurement from the fender lip (center of the wheel) to the ground. Then lift the car by the frame until the wheel is just touching the ground, re-measure. This will indicate how far you are from full extension of the shock. A minimum of 1.5" of extension travel (at the wheel) is needed to ensure that the shock does not top out. If you are more than 3" from full extension of the shock then you are in danger of bottoming out the shock absorber.

Adjusting Spring Height

When assembling the CoilOver, screw the spring retainer tight up to the spring (0 preload). After entire weight of car is on the wheels, jounce the suspension and roll the car forward and backward to alleviate suspension bind.

- If the car is too high w/ 0 preload then a smaller rate spring is required. Although threading the spring retainer down would lower the car, this could allow the spring to fall out of its seat when lifting the car by the frame.
- If the car is too low w/ 0 preload, then preload can then be added by threading the spring retainer up to achieve ride height. On 2.6" - 4" stroke shocks, up to 1.5" of preload is acceptable. On 5-7" stroke shocks, up to 2.5" of preload is acceptable. If more preload is needed to achieve ride height a stiffer spring rate is required. Too much preload may lead to coil bind, causing ride quality to suffer.

ridetech

Assembly...



First using the supplied lower adjuster nut(90002222) thread the nut onto the shock from the bottom side as seen in figure 1.



Next install delrin washers then coil spring over the top of the shock as seen in figure 2.



Before the upper spring mount can be installed screw the adjuster knob on the upper eye mount to the firmest setting (clockwise) as seen in figure 3. Then remove the Knob.



Once the knob is removed slide the Derlin washer over the spring, Next slide the upper spring mount (90002222) over eyelet as seen in figure 4.



Install upper spring mount retainer clip (90002057) into the groove on the upper eyelet as seen in figure 5. Then reinstall adjuster to complete assembly. **NOTE:** Remember to adjust the shock valving before driving, the shock is currently set to full stiff.

Shock adjustment 101- Single Adjustable

Rebound Adjustment:

How to adjust your new shocks.

The rebound adjustment knob is located on the top of the shock absorber protruding from the eyelet.

You must first begin at the ZERO setting, then set the shock to a medium setting of 12.



-Begin with the shocks adjusted to the ZERO rebound position (full stiff). Do this by rotating the rebound adjuster knob clockwise until it stops.



-Now turn the rebound adjuster knob counter clock wise 12 clicks. This sets the shock at 12. (settings 21-24 are typically too soft for street use).

Take the vehicle for a test drive.



-if you are satisfied with the ride quality, do not do anything, you are set!



-if the ride quality is too soft increase the damping effect by rotating the rebound knob clock wise 3 clicks.

Take the vehicle for another test drive.



-if the vehicle is too soft increase the damping effect by rotating the rebound knob clock wise 3 additional clicks.



-if the vehicle is too stiff rotate the rebound adjustment knob counter clock wise 2 clicks and you are set!

Take the vehicle for another test drive and repeat the above steps until the ride quality is satisfactory.

Note:

One end of the vehicle will likely reach the desired setting before the other end. If this happens stop adjusting the satisfied end and keep adjusting the unsatisfied end until the overall ride quality is satisfactory.