



350 S. St. Charles St. Jasper, In. 47546

Ph. 812.482.2932 Fax 812.634.6632

[www.ridetech.com](http://www.ridetech.com)

### Part # 19004900

## 4000lb. Air Over Leaf Kit – 2.5” Leaf / Side Frame

### Components:

|   |          |  |
|---|----------|--|
| 2 | 90006781 | 6.5” diameter double convoluted air spring |
| 2 | 90002495 | Leaf Spring Bracket                        |
| 2 | 90002494 | Leaf Spring Bracket Clamp                  |
| 2 | 90000070 | Air spring roll plate                      |
| 2 | 90000002 | Upper bolt-on bracket                      |
| 2 | 31954201 | ¼” npt x ¼” tube 90 degree airline fitting |

### Hardware:

|    |          |                         |  |
|----|----------|-------------------------|--|
| 2  | 99371001 | 3/8” x ¾” USS bolt      | Air spring to lower bracket                        |
| 2  | 99373005 | 3/8” lock washer        | Air spring to lower bracket                        |
| 4  | 99371047 | 3/8” Carriage Bolt      | Leaf Spring Bracket                                |
| 10 | 99373003 | 3/8” SAE flat washer    | Air spring mounting & Leaf Spring Bracket          |
| 8  | 99372002 | 3/8” USS Nylok nut      | Air spring to upper brackets & Leaf Spring Bracket |
| 8  | 99431002 | 7/16” x 1 1/4” USS bolt | Upper bracket to frame                             |
| 8  | 99433002 | 7/16” USS flat washer   | Upper bracket to frame                             |
| 8  | 99432001 | 7/16” Nylok nut         | Upper bracket to frame                             |



350 S. St. Charles St. Jasper, In. 47546  
Ph. 812.482.2932 Fax 812.634.6632  
[www.ridetech.com](http://www.ridetech.com)

**REAR INSTALLATION  
SUPPLEMENT FOR MOUNTING AIRSPRING ON TOP OF LEAFSPRING**

1. This installation is performed with the vehicle at ride height. When you raise the vehicle to a comfortable working height, support it by the axle housing.
2. Attach the lower airspring bracket to the top of the leafspring, preferably behind the rearend, using the attachment hardware provided. On some models, the lip of the airspring bracket will locate in the axle plate. **NOTE:** On some vehicles, a softer ride is obtained by removing leafs from the spring pack. Be sure to leave at least 2 leafs in the spring pack for stability.
3. Attach the airspring to the lower bracket.
4. The upper bracket can now be attached to the airspring and its placement on the framerail can be determined. If the leafspring is under the frame, the upper bracket will be a "J" shaped piece that the airspring screws into. If the leafspring is beside the frame, the upper bracket will be an angle bracket that will bolt on to the frame. Using the proper inflated dimensions, check for airspring clearance to nearby obstacles. [Refer to the airspring dimension chart.] Note that the proper inflated dimensions will not be the same as the uninflated dimensions.
5. Mark the bolt holes for drilling or clamp in place to weld. [Remove airspring before welding to avoid weld splatter damage!]
6. Reassemble, inflate, and re-inspect for proper clearance.

**NOTE: On the 88 -99 GM 1-ton chassis the F6781 airspring should be placed BEHIND the axle for the best clearance and the most load capacity.**

**REMEMBER: THE AIRSPRING BELLOWS MUST NOT TOUCH ANYTHING AT ANYTIME!! IT IS THE FINAL RESPONSIBILITY OF THE INSTALLER TO DETERMINE ADEQUATE CLEARANCE.**

**PLEASE CALL RIDETECH IF YOU HAVE ANY QUESTIONS.**

# Installation using 7000 Series or 9000 Series airspring

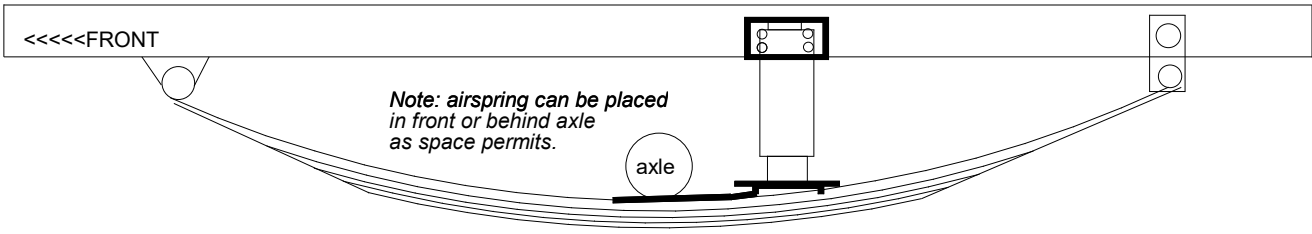

# Installation using F6781 Airspring

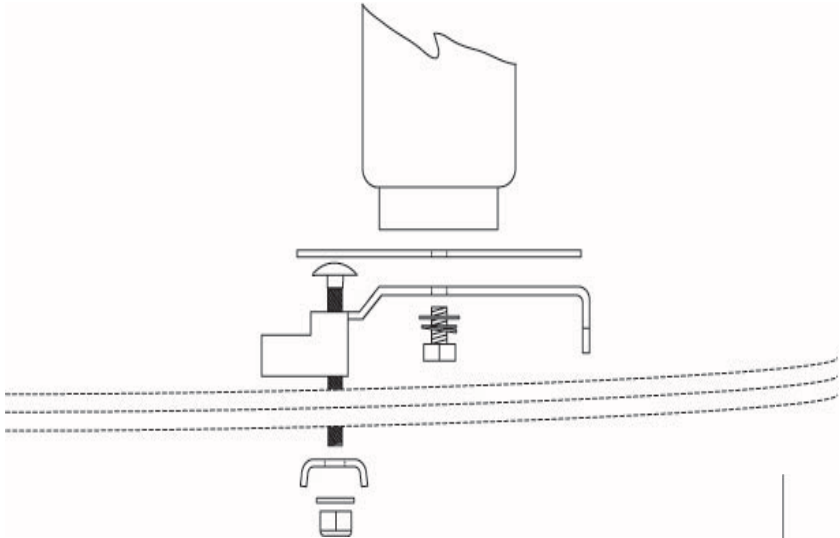
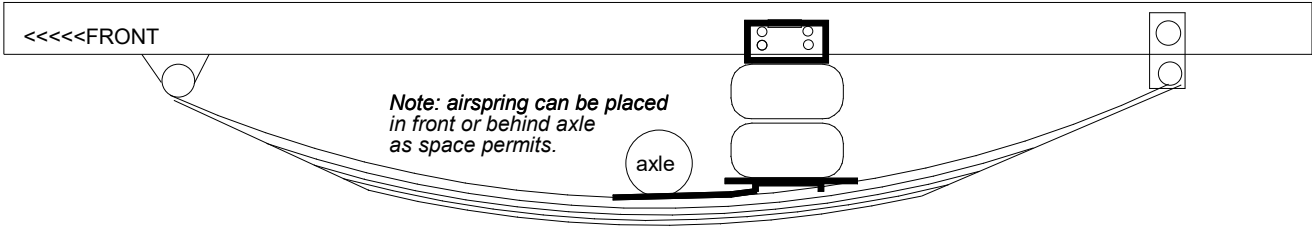

SIDE VIEW OF ASSEMBLY

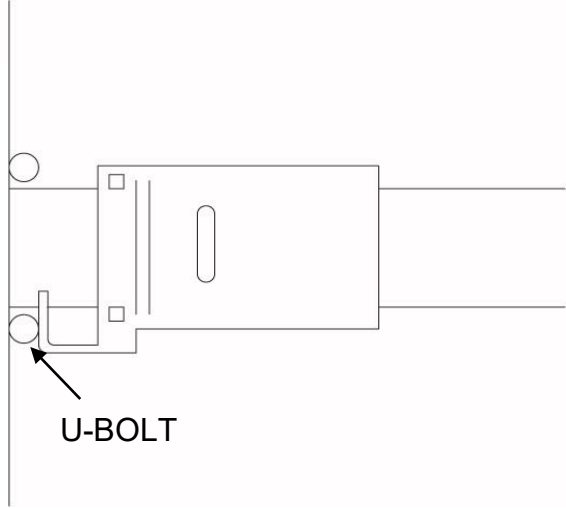
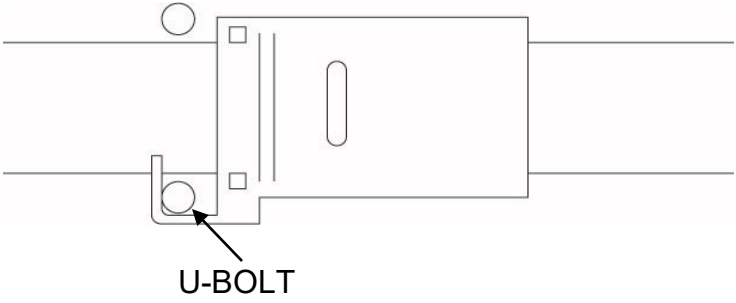

THE LEAF SPRING BRACKET CAN BE INSTALLED HOOKED ON THE U-BOLT OR TOUCHING U-BOLT AS SEEN IN ABOVE ILLUSTRATIONS.

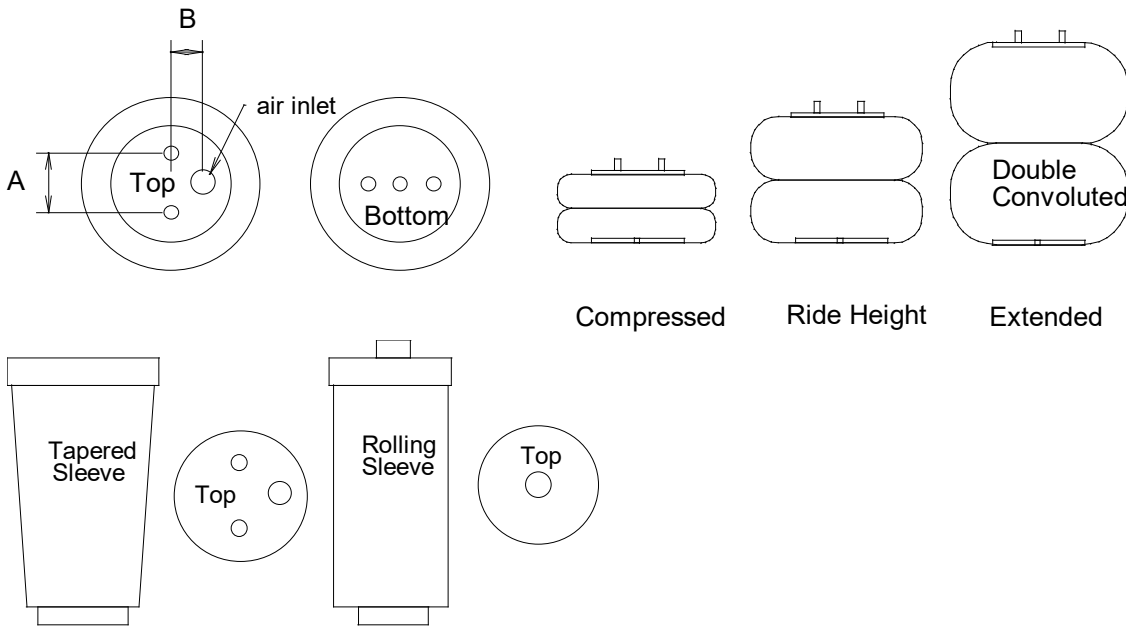

**AIRSPRING DIMENSION CHART**

| PART#           | TYPE              | Capacity @100psi | Compress Height       | Ride Height | Max. Height | Max Diameter | Bolt Pattern     |
|-----------------|-------------------|------------------|-----------------------|-------------|-------------|--------------|------------------|
| 255C<br>[F6781] | Double Convoluted | 2040#            | 3"[built in bumpstop] | 4.5"-5.5"   | 7"          | 6.5"         | A=1.75 B=.875    |
| 224C<br>[F0335] | Double Convoluted | 3150#            | 3"                    | 5"-6"       | 8"          | 8.0"         | A=2.75 B=1.312   |
| 26C<br>[F7325]  | Double Convoluted | 3400#            | 3"                    | 5"-6"       | 10"         | 8.5"         | A=2.75 B=1.312   |
| 20<br>[F6908]   | Double Convoluted | 4790#            | 3"                    | 7"-8"       | 11"         | 9.9"         | A=3.50 B=1.75    |
| F9000           | Tapered Sleeve    | 1500#            | 4.5                   | 8"-9.5"     | 13"         | 5"           | A=2.75 B=1.312   |
| F9002           | Tapered Sleeve    | 1500#            | 4.5                   | 7"-8.5"     | 12"         | 5"           | A=2.75 B=1.312   |
| F9003           | Tapered Sleeve    | 1500#            | 4.5                   | 6"-7"       | 11"         | 5"           | A=2.75 B=1.312   |
| F9010           | Tapered Sleeve    | 2000#            | 6.5"                  | 10.5"-11.5" | 16"         | 6.5"         | .750 SAE/.250npt |
| 7012            | Rolling Sleeve    | 1020#            | 4"                    | 7.5"-8.5"   | 13"         | 5"           | .750SAE/.125npt  |
| 7076            | Rolling Sleeve    | 800#             | 2.25"                 | 5"-6"       | 9"          | 4"           | .750SAE/.125npt  |

**CAUTION!!! EXCEEDING THESE DIMENSIONS MAY RESULT IN SUDDEN AIRSPRING FAILURE! PROPER CLEARANCES MUST BE MAINTAINED AT ALL RIDE HEIGHTS AND STEERING ANGLES. BUMPSTOPS MUST BE USED TO LIMIT SUSPENSION TRAVEL BEFORE THESE DIMENSIONS ARE EXCEEDED.**